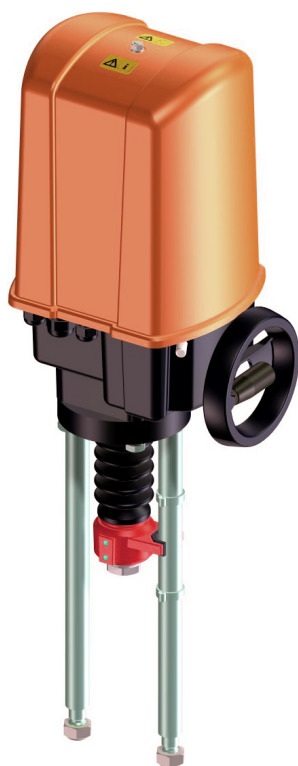

Large stroke actuator for 2-way and 3-way large globe valves DN 200 / DN 250

- Actuating force 12 kN
- Nominal voltage AC/DC 24 V
- Control: modulating DC 0 ... 10 V

Type listing

Type	Suitable for Belimo large globe valve
GV12-24-SR-T	H6..W..-S7 H7..W..-S7

Technical data

Electrical data	Nominal voltage	AC/DC 24 V, 50 Hz
	Nominal voltage range	AC/DC 18 ... 26.4 V
	Power consumption (Dimensioning)	65 VA
	Connection	Terminals, 2.5 mm ²
Functional data	Actuating force (Closing force)	12 kN
	Control Positioning signal Y	DC 0 ... 10 V, input impedance 500 kΩ
	Operating range	DC 2 ... 10 V (can be switched to 0.5 ... 10 V)
	Position feedback (measuring voltage U)	DC 2 ... 10 V (can be switched to 0.5 ... 10 V), max. 0.5 mA
	Nominal stroke	65 mm
	Actuating time	0.79 mm/s
	Sound power level	63 dB(A)
	Position indication	mechanical (30 ...)65 mm stroke
	Operating mode	EN60034-1/A11 S3-80% ED 1200 c/h
	Lubricant for gearbox	Molyduval Valenzia H2
Safety	Protection class	III Safety extra-low voltage
	Protection mode	IP65
	EMC	CE according to 2004/108/EC
	Mode of operation	Type 1 (EN 60730-1)
	Rated impulse voltage	2 kV (EN 60730-1)
	Control pollution degree	3 (EN 60730-1)
	Ambient temperature	-20 ... +70 °C
	Ambient humidity	95% r.h., non-condensing (EN 60730-1)
	Maintenance	Maintenance-free
	Dimensions / weight	Dimensions
Weight		Approx. 10.5 kg

Safety notes



- The actuator has been designed for use in stationary heating, ventilation and air conditioning systems and is not allowed to be used outside the specified field of application, especially in aircraft or in any other airborne means of transport.
- It may only be installed by suitably trained personnel. Any legal regulations or regulations issued by government agency authorities must be observed during assembly.
- The device does not contain any parts that can be replaced or repaired by the user.
- The device contains electrical and electronic components and is not allowed to be disposed of as household refuse. All locally valid regulations and requirements must be observed.

Product features

- Mode of operation** The actuator is activated with a standard DC 0 ... 10 V signal. If the actuator reaches the end position, then the motor will be switched off via (two) load-dependent switches. These switches protect the motor when there are foreign objects between the fitting seat and the cone.
- Installation actuator – valve** The actuator is mounted ex-works to the corresponding valve. The power connection is accomplished with form closure. The power transmission is accomplished by means of the coupling that is secured against torsion.
- Actuator replacement** If an actuator must be replaced in an emergency situation, then the installation instructions for replacement actuators must be followed.
- Manual override** In deenergised state and/or when the motor is shut off, upward and downward movement can be accomplished when the handwheel is pressed in.

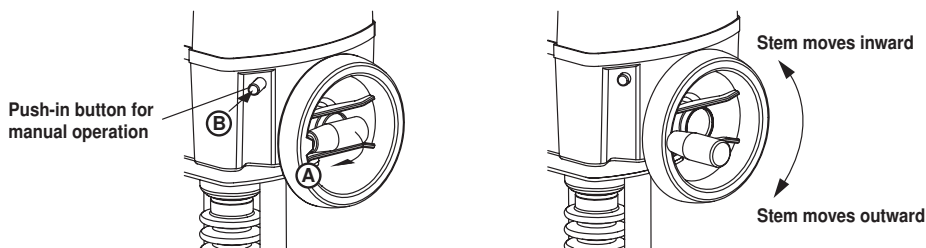

Caution

- Manual operation may be initiated only when the motor is shut off. Switching while the motor is running can cause damage to the stroke actuator!
- When in manual operation, do not fail to note that, when in end position, the handwheel is rotated only to the point that the torque switches are actuated (audible clicking), because otherwise the stroke actuator will be damaged.



- To accomplish this, proceed as follows:
- Unfold rotary handle from the handwheel (A)
 - Press in the engagement button for manual operation while rotating the handwheel slightly (B)
 - Rotate handwheel in clockwise direction → Stem moves outward ↓
 - Rotate handwheel anticlockwise → Stem moves inward ↑

Settings / parameterisation

Reset and initialisation

- Reset (press <2 s): Restart of software and deletion of stored errors is carried out
- Initialisation (press >2 s): Actuator travels to end stops and determines the valve stroke while doing so (Note: «Init» is to be carried out after assembly)

Operating mode of the actuator: Open, Stop, Close, Auto

- Presetting Auto (below): Actuator follows the positioning signals

Positioning signal configuration: 0/2...10V

- Presetting control voltage: 2...10V (below)

Signal inversion

- Signal inversion presetting: NOT inverted (below)
- Setting: **not inverted** (below) with installation on H6..W..-S7
- Setting: **inverted** (above) with installation on H7..W..-S7

Characteristic curve

- Characteristic curve correction presetting: Linear (below)

Default setting for all adjustable rocker switches thus = **below**

Product features

(continued)

LED status displays

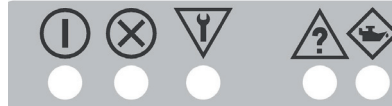

LED	Colour	Meaning	Description / explanation
	green	Power	Electronics is supplied with voltage
	red	Fault	Actuator is not initialised, actuator cannot reach the setpoint position (for better localisation of the cause of failure, see the «LED coding for errors» below)
	orange	Functional check	Blockade, manual operation (handwheel or slide switch)
	yellow	Does not comply with specification	The LED lights up when the following parameters are exceeded: – ED (Power-on time) – Temperature range – Flashing during the initialisation run
	blue	Maintenance	Dirty stroke detection → please clean up

LED coding with faults

No initial run	green	red			
Blockade	green	red	orange		
Y in positioning signal has failed	green	red		yellow	
ADV – outside the valid travel path	green	red	orange	yellow	
Position cannot be reached	green	red	orange		blue
Valve stroke too small	green	red	orange	yellow	blue

High operational reliability

The actuator is protected against short circuits, polarity reversal and overloading.

Function indication

The stroke is indicated mechanically on the bracket. The indicator adjusts itself automatically.

Electrical installation

Wiring diagram

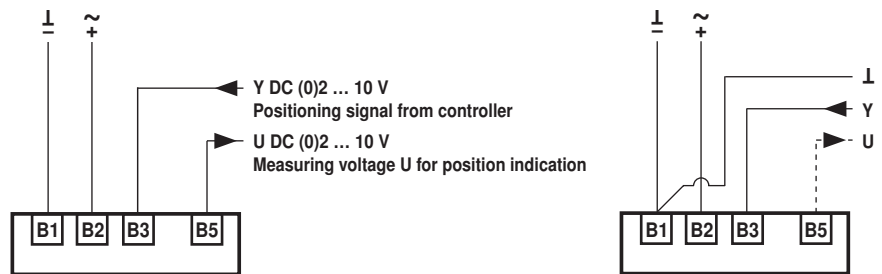

Notes

- Connection via safety isolating transformer.
- Shared ground for supply and signal with max. conductor lengths of 25 m with 1.5 mm² conductor cross-section or 10 m with 0.75 mm² conductor cross-section. Guide supply and signal separately with longer signal cable lengths (Ground Signal).
- Use twisted cables.

			A – AB
Y = 0/2 V	↓	↑	0 %
Y = 10 V	↑	↓	100 %

Dimensions [mm]

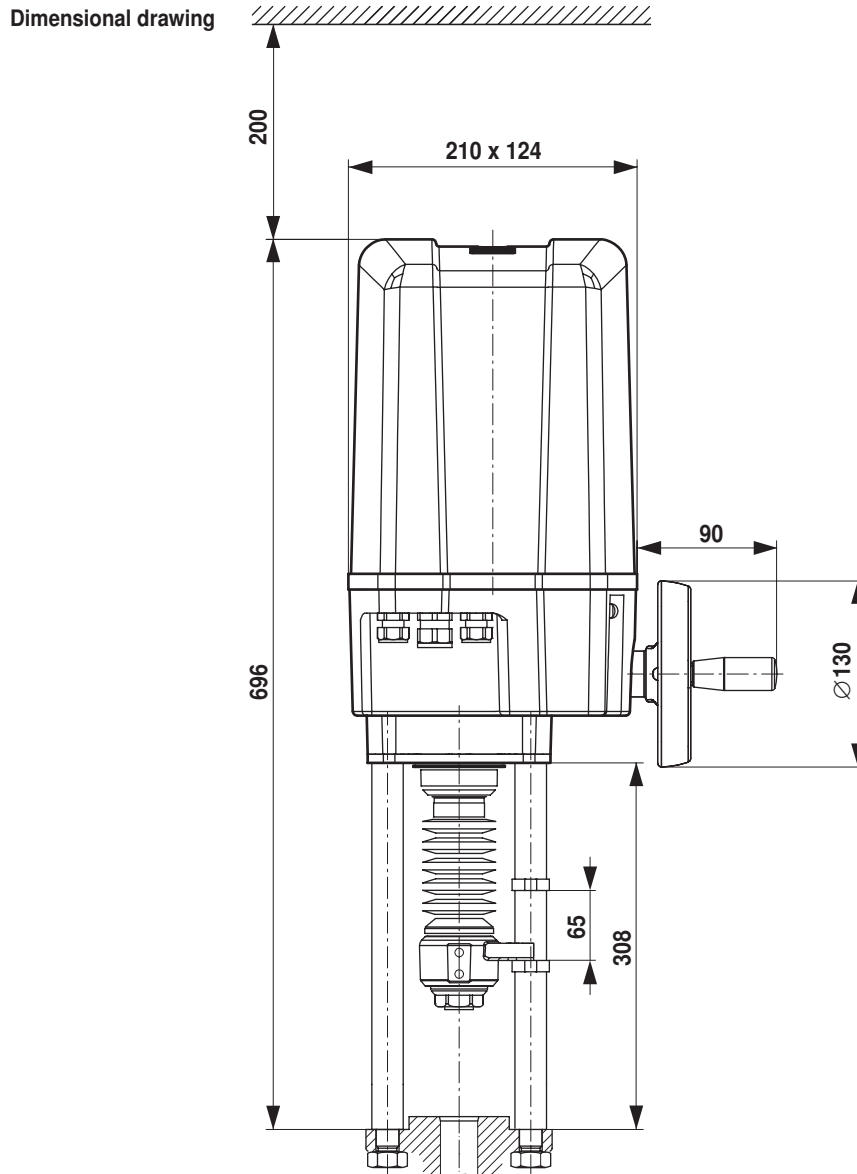
**Further documentation**

- Complete overview «Overview Valve-actuator combinations»
- Data sheets large globe valves
- Installation instructions for actuators and large globe valves, respectively
- Notes for project planning (hydraulic characteristic curves and circuits, installation regulations, commissioning, maintenance, etc.)