

Globe valve, 3-way, Flange, PN 40

- For closed cold water, low-temperature hot water and hot water systems
- For water-side modulating control of air-handling and heating systems

Type overview

Type	DN []	kvs [m ³ /h]	Stroke [mm]	PN []	Sv min. []
H7015Y4-S2	15	4	20	40	30
H7020Y6P3-S2	20	6.3	20	40	50
H7025Y10-S2	25	10	20	40	50
H7032Y16-S2	32	16	20	40	50
H7040Y25-S2	40	25	20	40	50
H7050Y40-S2	50	40	20	40	50
H7065Y63-S4	65	63	30	40	50
H7080Y100-S4	80	100	30	40	50
H7100Y160-S4	100	160	30	40	50

Technical data

Functional data	Media	Cold and warm water, water with glycol up to max. 50% vol.
	Medium temperature	5...200 °C
	Medium temperature note	120 °C up to 4000 kPa 200 °C up to 3200 kPa
	Permissible pressure ps	4000 kPa
	Flow characteristic	Control path A – AB: linear (VDI/VDE 2173), Bypass B – AB: linear (VDI/VDE 2173)
	Leakage rate	Control path A - AB: max. 0.05% of the kvs value, Bypass B - AB: max. 1% of the kvs value
	Pipe connectors	Flange according to ISO 7005-2 (PN 40)
	Closing point	Top (▲)
	Installation position	Upright to horizontal (in relation to the stem)
	Maintenance	Maintenance-free
Materials	Housing	Cast steel 1.0619N
	Closing element	Stainless steel
	Stem	Stainless steel
	Stem seal	PFTE V-ring
	Seat	Stainless steel

Safety notes



- The valve has been designed for use in stationary heating, ventilation and air-conditioning systems and is not allowed to be used outside the specified field of application, especially in aircraft or in any other airborne means of transport.
- Only authorised specialists may carry out installation. All applicable legal or institutional installation regulations must be complied during installation.
- The valve does not contain any parts that can be replaced or repaired by the user.
- The valve may not be disposed of as household refuse. All locally valid regulations and requirements must be observed.
- When determining the flow rate characteristic of controlled devices, the recognised directives must be observed.

Product features

- Mode of operation** The globe valve is adjusted by a globe valve actuator. The actuators are controlled by a commercially available modulating or 3-point control system and move the valve cone, which acts as a mixing device, to the opening position dictated by the positioning signal.
- Flow characteristic** A linear flow characteristic is produced in the direction of flow by the profile of the valve cone. The bypass exhibits a linear characteristic curve.

Installation notes

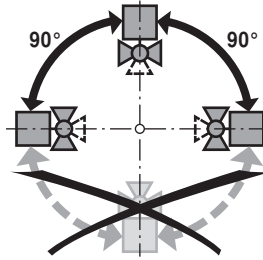
- Recommended installation positions** The globe valve may be mounted upright to horizontal. It is not permissible to mount the globe valves with the spindle pointing downwards.



- Water quality requirements** The water quality requirements specified in VDI 2035 must be adhered to. Belimo valves are regulating devices. For the valves to function correctly in the long term, they must be kept free from particle debris (e.g. welding beads during installation work). The installation of suitable strainer is recommended.

- Maintenance** Globe valves and globe valve actuators are maintenance-free. Before any kind of service work is carried out on the actuator, it is essential to isolate the globe valve actuator from the power supply (by disconnecting the electrical cables if necessary). Any pumps in the part of the piping system concerned must also be switched off and the appropriate shut-off valves closed (allow everything to cool down first if necessary and reduce the system pressure to ambient pressure level). The system must not be returned to service until the globe valve and the globe valve actuator have been mounted properly in accordance with the instructions and the pipes have been refilled in the proper manner.

- Flow direction** The direction of flow, specified by an arrow on the housing, is to be complied with, since otherwise the valve could become damaged.

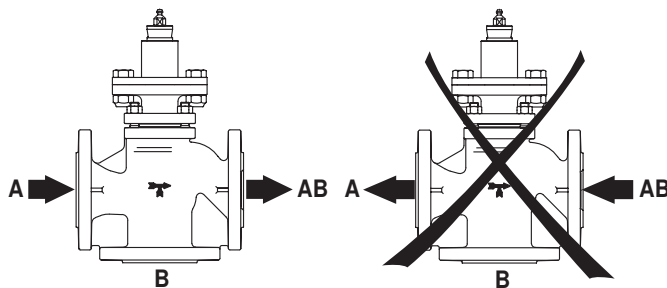

Dimensions / Weight

Dimensional drawings

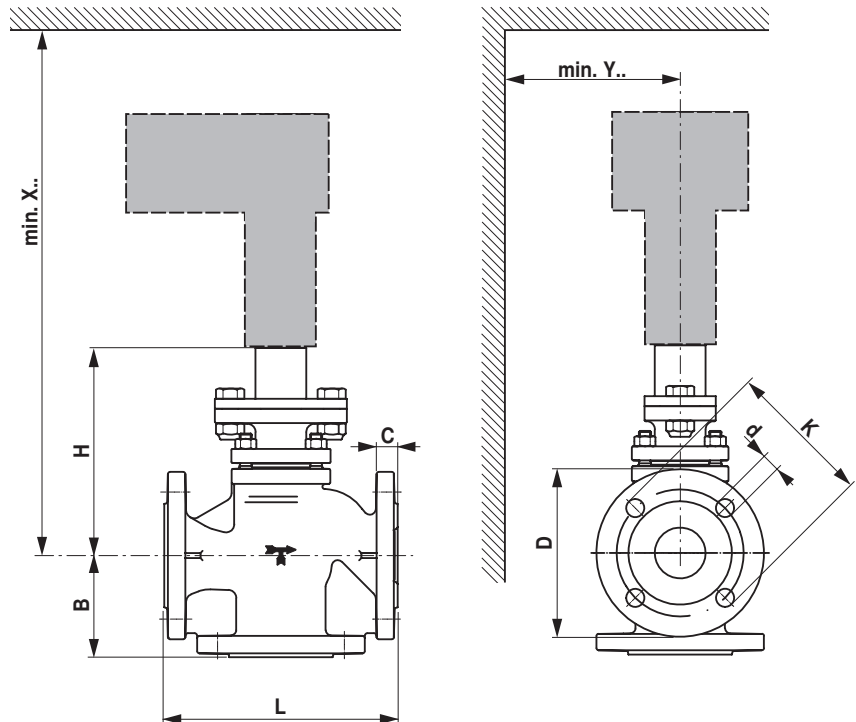

X/Y: Minimum distance with respect to the valve centre.
The actuator dimensions can be found on the respective actuator data sheet.

Type	DN []	L [mm]	B [mm]	H [mm]	C [mm]	D [mm]	d [mm]	K [mm]	X [mm]	Y [mm]	Weight approx. [kg]
H7015Y4-S2	15	130	65	172	16	95	4 x 14	65	400	100	6.7
H7020Y6P3-S2	20	150	70	172	18	105	4 x 14	75	400	100	7.8
H7025Y10-S2	25	160	75	176	18	115	4 x 14	85	410	100	8.8
H7032Y16-S2	32	180	80	202	18	140	4 x 18	100	430	100	11.7
H7040Y25-S2	40	200	90	207	18	150	4 x 18	110	440	100	15.3
H7050Y40-S2	50	230	100	205	20	165	4 x 18	125	440	100	17.4
H7065Y63-S4	65	290	120	230	22	185	8 x 18	145	560	150	25
H7080Y100-S4	80	310	130	246	24	200	8 x 18	160	580	150	34
H7100Y160-S4	100	350	150	265	24	235	8 x 22	190	600	150	52

Further documentation

- Overview Valve-actuator combinations
- Data sheets for globe valve actuators
- Installation instructions for valves and/or globe valve actuators
- Notes for project planning 2-way and 3-way globe valves