

Open/close ball valve, 2-way, External thread

- For open and closed cold and warm water systems
- For shut-off functions on the water side and 2-point controls in air-handling units and heating systems.
- for potable water on request
- Air-bubble tight



Type overview

| Type | DN | G ["] | Kvs [m ³ /h] | PN |
|------|----|----------|----------------------------|----|
| R415 | 15 | 1 | 8.6 | 40 |
| R420 | 20 | 1 1/4 | 21 | 40 |
| R425 | 25 | 1 1/2 | 26 | 40 |
| R432 | 32 | 2 | 32 | 25 |
| R440 | 40 | 2 1/4 | 32 | 25 |
| R450 | 50 | 2 3/4 | 49 | 25 |

Technical data

| | | | |
|------------------------|--|--|--------------------------|
| Functional data | Fluid | Cold and hot water, potable water (on request), water with glycol up to max. 50% vol. | |
| | Fluid temperature | -10...100°C [14...212°F] | |
| | Fluid temperature note | At a fluid temperature of -10...2°C, a valve neck extension is recommended. The allowed fluid temperature can be limited, depending on the type of actuator. Limitations can be found in the respective data sheets of the actuators. | |
| | Close-off pressure Δp_s | 1400 kPa | |
| | Differential pressure Δp_{max} | 400kPa | |
| | Differential pressure note | 200 kPa for low-noise operation | |
| | Leakage rate | air-bubble tight, leakage rate A (EN 12266-1) | |
| | Angle of rotation | 90° | |
| | Pipe connection | External thread according to ISO 228-1 | |
| | Installation orientation | upright to horizontal (in relation to the stem) | |
| | Servicing | maintenance-free | |
| | Materials | Valve body | Nickel-plated brass body |
| | | Body finish | nickel-plated |
| Closing element | | Stainless steel | |
| Spindle | | Stainless steel | |
| Spindle seal | | EPDM O-ring | |
| Seat | | PTFE, O-ring Viton | |
| Grease | | Klübersynth VR 69-252N (potable water grade) | |

Safety notes



- The valve has been designed for use in stationary heating, ventilation and air-conditioning systems and must not be used outside the specified field of application, especially in aircraft or in any other airborne means of transport.
- Only authorised specialists may carry out installation. All applicable legal or institutional installation regulations must be complied with during installation.
- The valve does not contain any parts that can be replaced or repaired by the user.
- The valve may not be disposed of as household refuse. All locally valid regulations and requirements must be observed.
- When determining the flow rate characteristic of controlled devices, the recognised directives must be observed.

Product features

Operating mode The open/close ball valve is adjusted by a rotary actuator. The rotary actuator is connected by an open/close signal. Open the ball valve counterclockwise and close it clockwise.

Accessories

| Electrical accessories | Description | Type |
|------------------------|--|-----------|
| | Stem heater DN 15...50 (20 W) | ZR24-2 |
| Mechanical accessories | Description | Type |
| | Valve neck extension for ball valve DN 15...50 | ZR-EXT-01 |
| | Pipe connector for ball valve with external thread DN 15 Rp 1/2" | ZR4515 |
| | Pipe connector for ball valve with external thread DN 20 Rp 3/4" | ZR4520 |
| | Pipe connector for ball valve with external thread DN 25 Rp 1" | ZR4525 |
| | Pipe connector for ball valve with external thread DN 32 Rp 1 1/4" | ZR4532 |
| | Pipe connector for ball valve with external thread DN 40 Rp 1 1/2" | ZR4540 |
| | Pipe connector for ball valve with external thread DN 50 Rp 2" | ZR4550 |

Installation notes

Permissible installation orientation The ball valve can be installed upright to horizontal. The ball valve may not be installed in a hanging position, i.e. with the spindle pointing downwards.

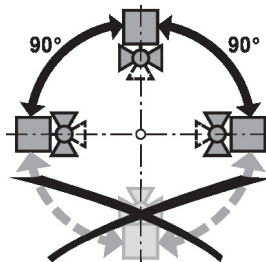

Water quality requirements The water quality requirements specified in VDI 2035 must be adhered to. Belimo valves are regulating devices. For the valves to function correctly in the long term, they must be kept free from particle debris (e.g. welding beads during installation work). The installation of a suitable strainer is recommended.

Installation notes

Servicing Ball valves and rotary actuators are maintenance-free.

Before any service work on the control element is carried out, it is essential to isolate the rotary actuator from the power supply (by unplugging the electrical cable if necessary). Any pumps in the part of the piping system concerned must also be switched off and the appropriate slide valves closed (allow all components to cool down first if necessary and always reduce the system pressure to ambient pressure level).

The system must not be returned to service until the ball valve and the rotary actuator have been correctly reassembled in accordance with the instructions and the pipeline has been refilled by professionally trained personnel.

Flow direction The direction of flow, specified by an arrow on the housing, is to be complied with, since otherwise the ball valve could become damaged. Please ensure that the ball is in the correct position (marking on the spindle).

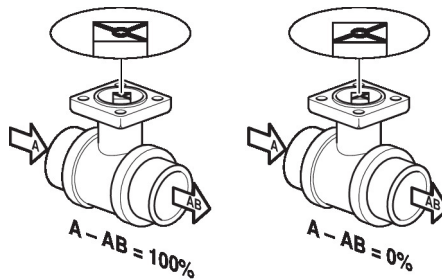

Dimensions

Dimensional drawings

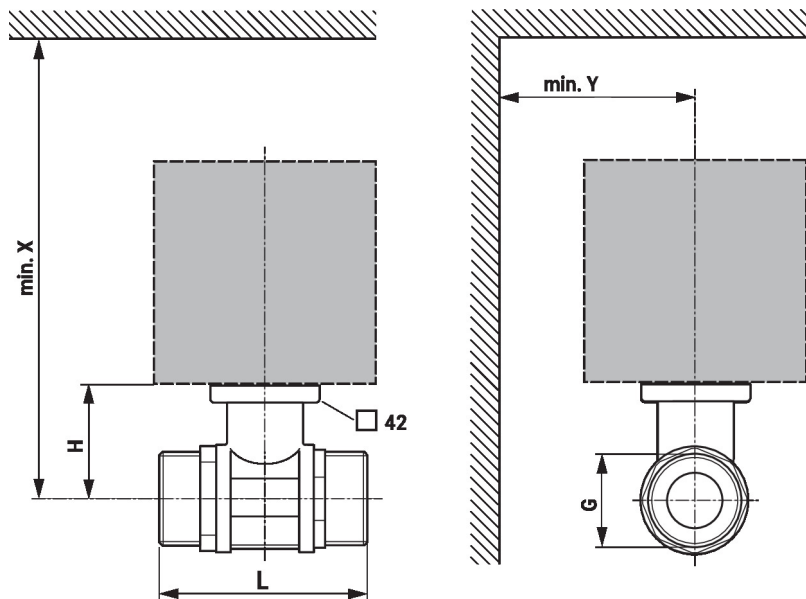

X/Y: Minimum distance with respect to the valve centre.
The actuator dimensions can be found on the respective actuator data sheet.

| Type | DN | G ["] | L [mm] | H [mm] | X [mm] | Y [mm] | kg |
|------|----|----------|-----------|-----------|-----------|-----------|------|
| R415 | 15 | 1 | 74 | 44 | 220 | 90 | 0.50 |
| R420 | 20 | 1 1/4 | 85.5 | 46 | 220 | 90 | 0.76 |
| R425 | 25 | 1 1/2 | 84.5 | 46 | 220 | 90 | 0.77 |
| R432 | 32 | 2 | 102 | 50.5 | 230 | 90 | 1.2 |
| R440 | 40 | 2 1/4 | 103 | 50.5 | 230 | 90 | 1.1 |
| R450 | 50 | 2 3/4 | 115.5 | 56 | 240 | 90 | 2.1 |

Further documentation

- The complete product range for water applications
- Data sheets for actuators
- Installation instructions for actuators and/or ball valves
- General notes for project planning